

SE15H (□ 15 x 18mm)

Metal Brush



Weight:13.3g

Applications

Automotive, Amusement

External Dimensions

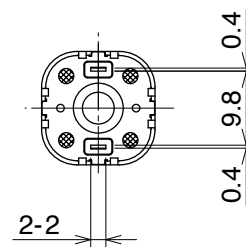
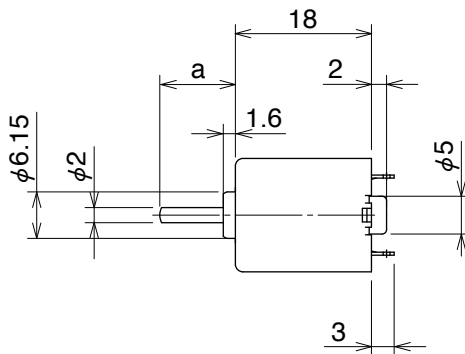
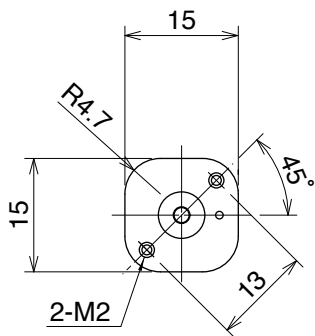

a=13.4mm、14.8mm

Unit:mm

Reference Characteristics

Model	Voltage		No Load		Rated Load		Rated Load		Starting Torque		Starting Current (mA)	Shaft Length (mm)
	Operating	Rated	Speed	Current			Speed	Current				
	(V)	(V)	(min ⁻¹)	(mA)	(gf·cm)	(mN·m)	(min ⁻¹)	(mA)	(gf·cm)	(mN·m)		
SE15H0RTY	8 to 13	12	5315	40	15.3	1.50	3916	118	58.2	5.70	335	13.4
SE15H0WTY	8 to 13	12	10200	80	20.4	2	8030	275	96	9.41	1000	13.4

Characteristics

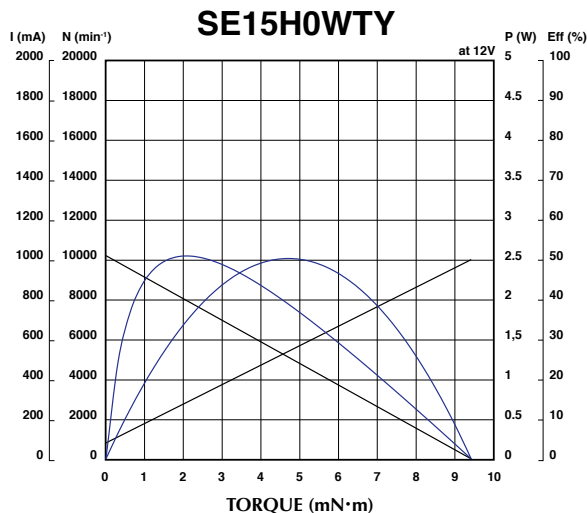
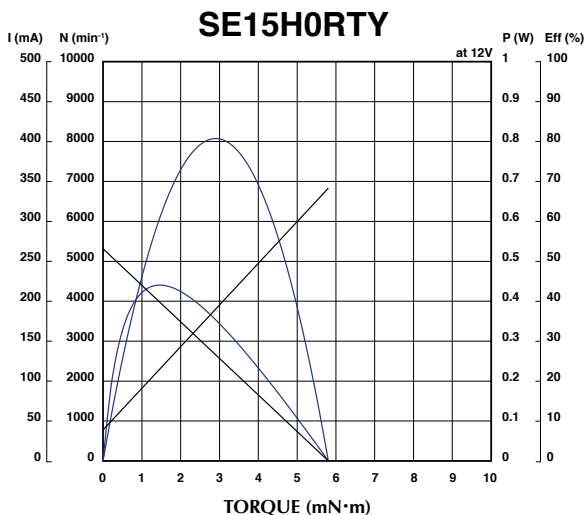

SE15K (□ 15 x 25mm)

Metal Brush

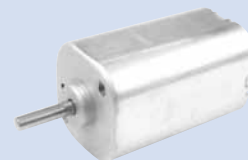

Weight:20.8g

Applications

Robot, Door Lock

External Dimensions

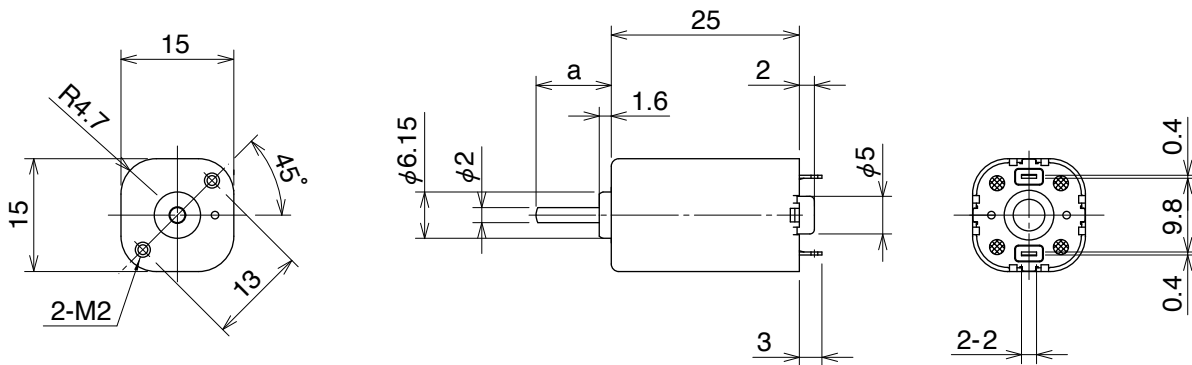

a=9.9mm

Unit: mm

Reference Characteristics

Model	Voltage		No Load		Rated Load		Rated Load		Starting Torque		Starting Current (mA)	Shaft Length (mm)
	Operating (V)	Rated (V)	Speed (min ⁻¹)	Current (mA)			Speed (min ⁻¹)	Current (mA)				
	(V)	(V)	(min ⁻¹)	(mA)	(gf·cm)	(mN·m)	(min ⁻¹)	(mA)	(gf·cm)	(mN·m)		
SE15K0TTY	8 to 13	12	3935	29	15.3	1.50	3265	85	89.8	8.80	360	9.9
SE15K1BTY	8 to 13	12	6780	52	25.5	2.50	6585	205	141	13.9	905	9.9

Characteristics

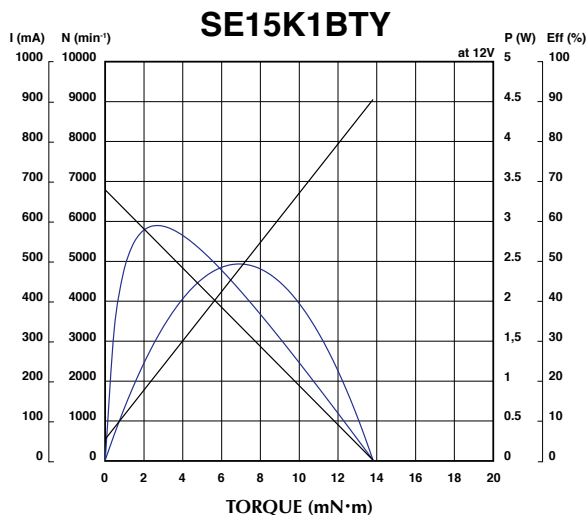
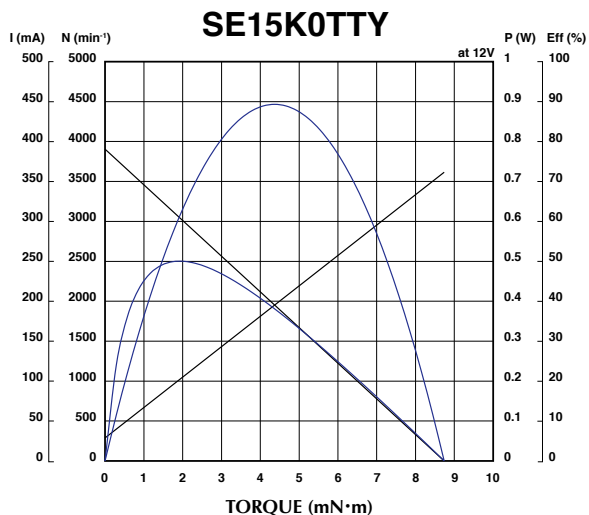

SE15M (□ 15 x 30mm)

Metal Brush



Weight: 27.3g

Applications

Printer, Projector

External Dimensions

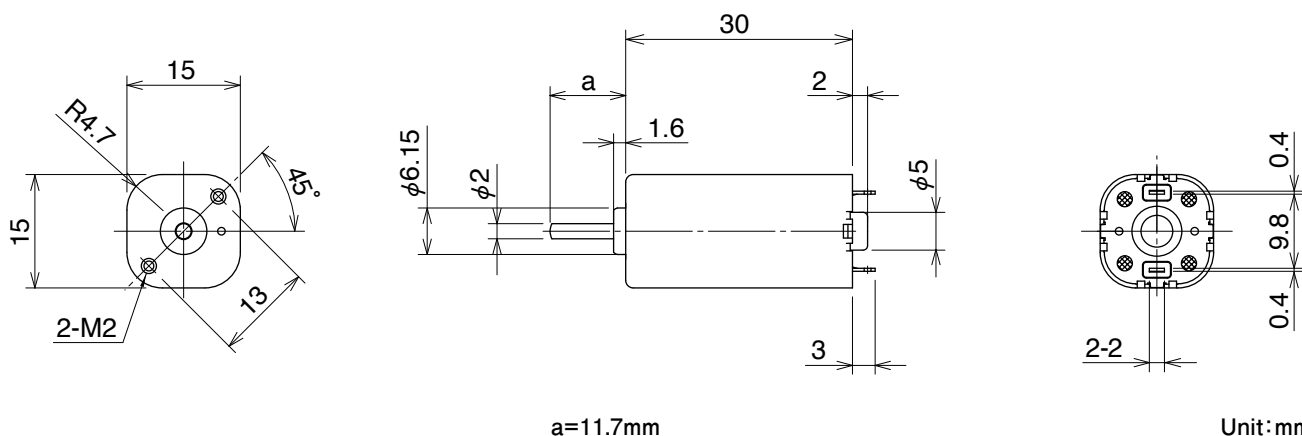

Reference Characteristics

Model	Voltage		No Load		Rated Load		Rated Load		Starting Torque		Starting Current	Shaft Length
	Operating	Rated	Speed	Current			Speed	Current				
	(V)	(V)	(min ⁻¹)	(mA)	(gf·cm)	(mN·m)	(min ⁻¹)	(mA)	(gf·cm)	(mN·m)	(mA)	(mm)
SE15M0WTY	8 to 13	12	4320	35	20.4	2	3475	124	104	10.2	490	11.7
SE15M1GTY	8 to 13	12	8100	95	40.8	4	6400	400	197	19.3	1580	11.7

Characteristics

